



Rotary Screw Compressors

FSD Series

With the world-renowned SIGMA PROFILE

Flow rate 9.65 to 61.4 m³/min, Pressure 5.5 to 15 bar

FSD Series

Setting the standard

KAESER KOMPRESSOREN pushes the boundaries of compressed air availability and efficiency once again with its latest generation of **FSD** series rotary screw compressors. Intelligent design solutions have not only lead to enhanced ease of operation and serviceability, but also give this series of class-defining compressors their distinctive modern appearance.

FSD – Energy savings as standard

Delivering improved specific power, the flow-optimised and further refined SIGMA PROFILE rotors provide the foundation for exceptional energy efficiency. The use of high performance IE4 drive motors maximises energy efficiency, whilst KAESER's 1:1 drive design eliminates the transmission losses associated with gear or V-belt driven systems, as the motor directly drives the airend. Furthermore, the radial fan fulfils the efficiency requirements for fans as per EU directive 327/2011. Last, but not least, the advanced SIGMA CONTROL 2 compressor controller achieves additional energy savings and minimises cost-intensive idling periods through the use of a variety of specially developed control options, e.g. Dynamic control.

Service-friendly = Efficient

The distinctive and eye-catching design of these systems from the outside is complemented by intelligent component layout on the inside for even greater energy efficiency: for example, all service and maintenance points are within easy reach and directly accessible from the front of the unit. This not only saves time and money when performing service work, but also maximises compressed air system availability.

Perfect partners

FSD series rotary screw compressors are the perfect partners for high-efficiency industrial compressed air stations. The internal SIGMA CONTROL 2 compressor controller offers numerous communications interfaces (e.g. Ethernet), which, when connected within the KAESER SIGMA NETWORK, allows seamless communication with advanced master controllers, such as KAESER's SIGMA AIR MANAGER 4.0, and in-house centralised control systems. This enables simple set-up and achieves unprecedented levels of efficiency.

Electronic Thermal Management

Powered via an electric motor, the sensor-controlled temperature control valve integrated into the cooling circuit is the heart of the innovative Electronic Thermal Management (ETM) system. The SIGMA CONTROL 2 compressor controller monitors intake and compressor temperature in order to prevent condensate formation, even under conditions with higher air humidity. ETM dynamically controls the fluid temperature and low fluid temperature enhances energy efficiency. FSD packages are equipped with a additional ETM systems if heat recovery is used. This enables heat recovery to be better adapted to the customer's exact requirements.

Why choose heat recovery?

The question should in fact be: Why not? Amazingly, up to 100 % of the (electrical) energy input to a compressor is converted into heat. Up to 96 % of this energy can be recovered and reused for heating purposes. This not only reduces primary energy consumption, but also significantly improves the applicable company's total energy balance.

Up to
96%
usable for heating



Service-friendly



Image: FSD 575, air-cooled



FSD series

Energy savings in every detail



Save energy with the SIGMA PROFILE

At the heart of every FSD system lies a premium quality airend featuring KAESER's SIGMA PROFILE rotors. Operating at low speed, KAESER's airends are equipped with flow-optimised rotors for superior efficiency and performance.



SIGMA CONTROL 2: optimum efficiency

The internal SIGMA CONTROL 2 controller ensures efficient compressor control and monitoring at all times. The large display and RFID reader provide easy communication and maximum security. Variable interfaces enable seamless networking capability, whilst the SD card slot makes updates quick and easy.



Tomorrow's technology, today: IE4 Motors

KAESER is currently the only compressed air systems provider to equip its compressors with super premium efficiency IE4 motors as standard, thereby delivering maximum performance and energy efficiency.



Correct temperature assured

According to operating conditions, the innovative Electronic Thermal Management (ETM) system dynamically controls fluid temperature to ensure safe prevention of condensation accumulation and also boosts energy efficiency.

FSD series

Efficient in every way



Dependable condensate pre-separation

Integrated as standard, the KAESER axial centrifugal separator with electronic ECO-DRAIN condensate drain provides an exceptionally high degree of separation (>99 %) with minimal pressure loss. Dependable and efficient condensate separation is therefore assured at all times, even under conditions with high ambient temperatures and humidity.



Optimised intake valve

The new flow-optimised design of the inlet valve helps minimise intake pressure losses and simplifies servicing.



Environmentally-friendly fluid filter

The eco-filter elements, housed in the aluminium fluid filter enclosure, are 'metal-free'. They can therefore simply be disposed of thermally at the end of their service life.



Energy-saving 1:1 direct drive

With 1:1 direct drive, the drive motor and airend – together with the coupling and coupling flange – form a compact durable unit that operates with zero drive losses.

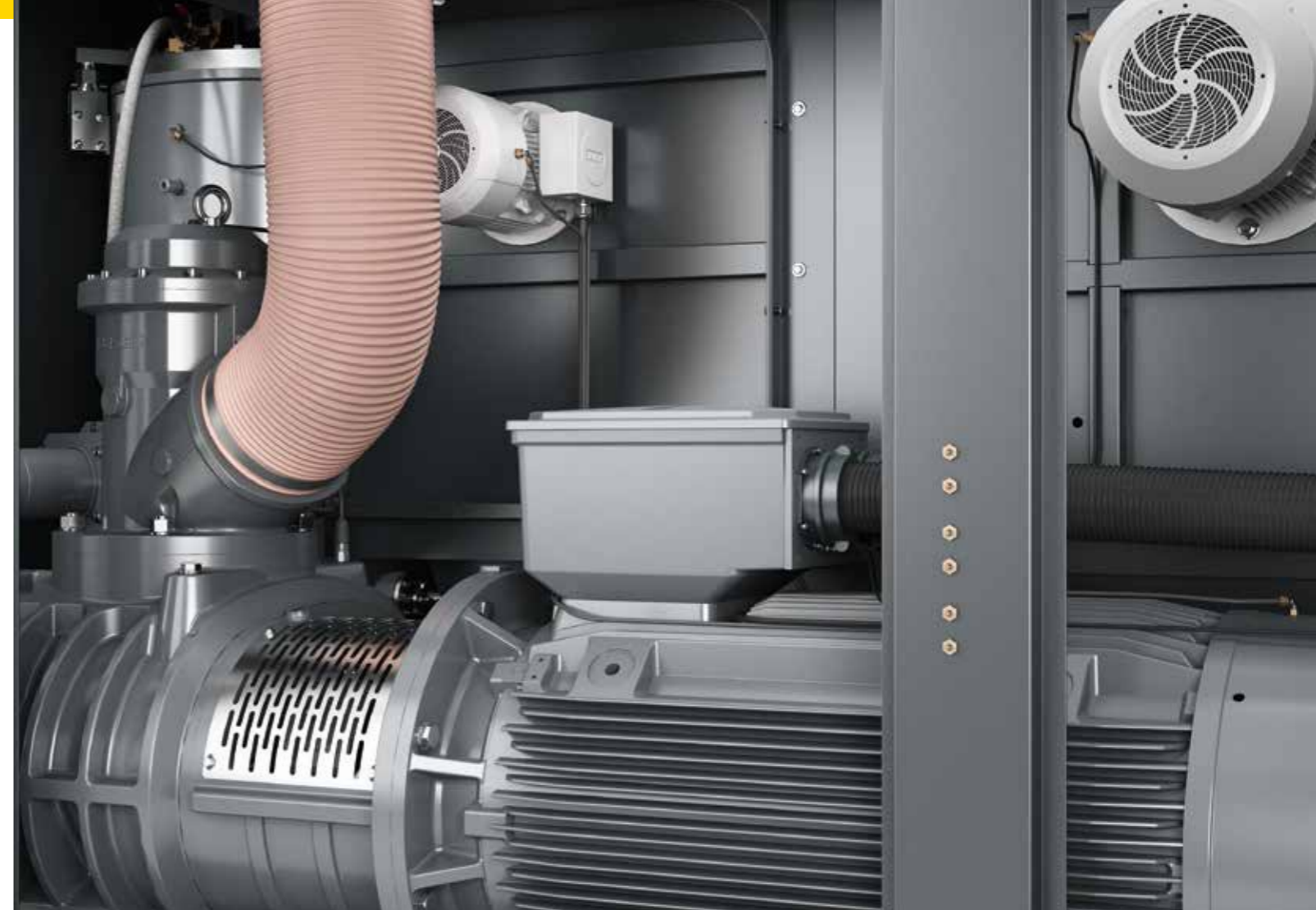

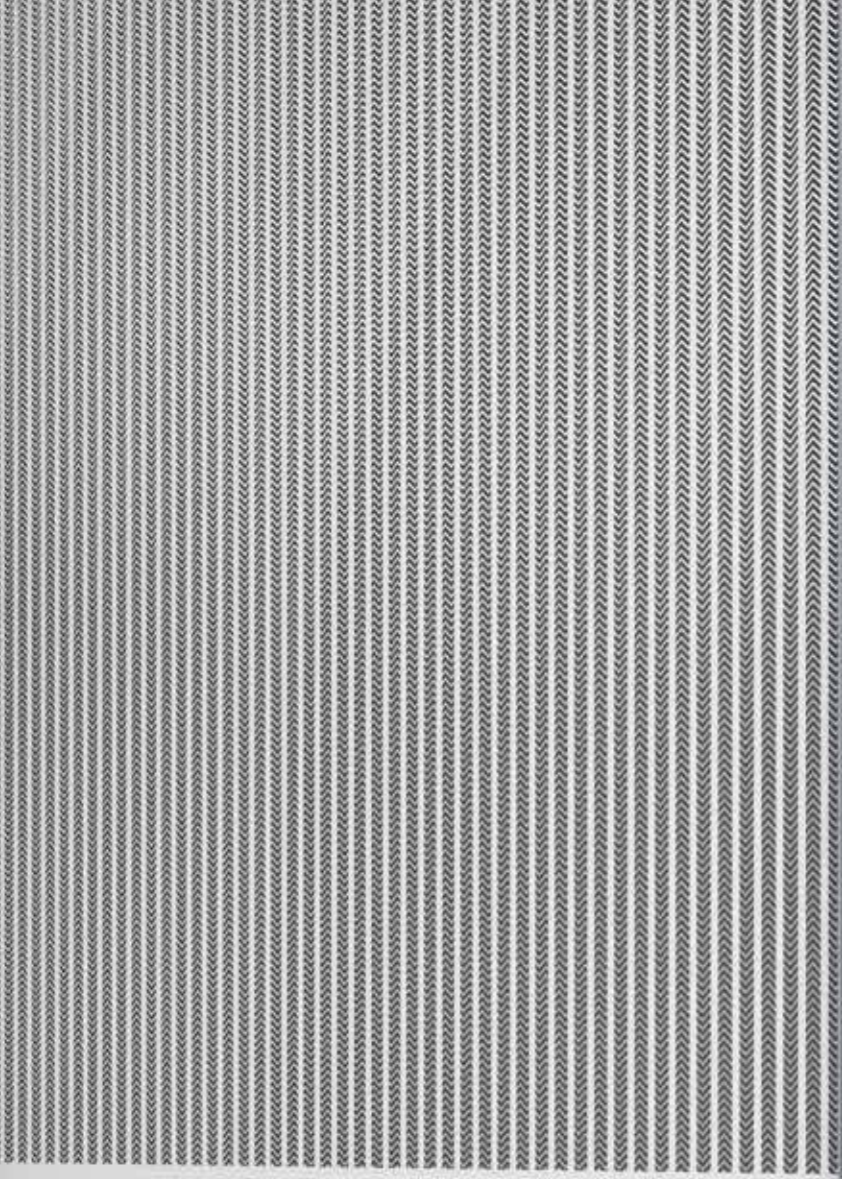

FSD series

Clever cooling, significant savings



Low operating temperature

Thermostat controlled fans with variable speed motors produce the exact amount of cooling air required by the fluid cooler to ensure low operating temperatures. This significantly reduces the overall energy demand of FSD rotary screw compressor systems.



Low compressed air temperature

Effective aftercooling helps maintain low compressed air discharge temperature. This, in combination with the centrifugal separator, removes large volumes of condensate which is then drawn off without energy loss via the electronically controlled ECO-DRAIN condensate drain. In turn, the burden on downstream treatment equipment is also reduced.



Coolers cleaned from the outside

Unlike internally installed heat exchangers, the externally installed coolers in FSD systems are easy to access and simple to clean. Operational reliability and availability are therefore enhanced, as contaminant build-up is easily spotted.



High residual thrust exhaust air

The integrated radial fans are considerably more efficient than axial fans and provide high residual thrust. This generally enables the warm exhaust air to be directly ducted away without the need for an auxiliary fan.

Service-friendly

Excellent accessibility

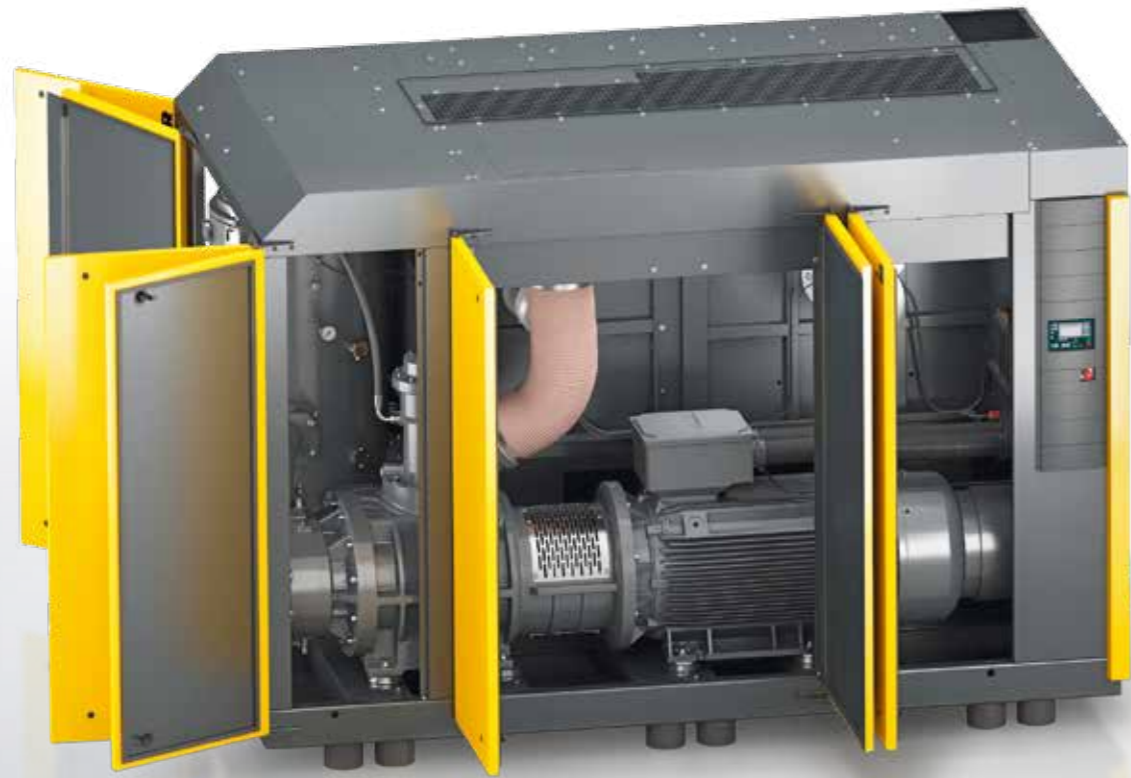

Image: FSD 575, air-cooled



Oil separator cartridge replacement

The cartridge can be replaced easily from the top; removal of just one enclosure section on the top is required. The oil separator tank cover can be swung out inside the system.



External lubrication

Electric motors must be lubricated while running. In FSD systems, service staff can easily perform this task for the drive and fan motors from the outside of the machine, thereby ensuring maximum safety.

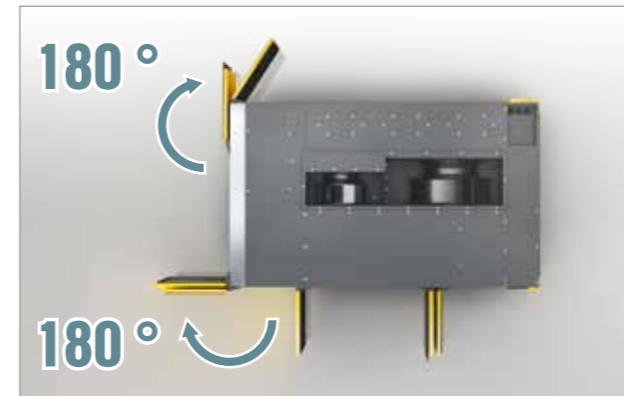

Service doors open 180°

The wide-opening service doors allow excellent accessibility to all components for maximum ease of service. This speeds up service work, which reduces operating costs and increases availability.



Easy replacement of maintenance parts

Just like the air filter, which is changed from the front of the unit, all other maintenance parts are easily accessible. Thanks to the intake filter's additional pre-separation filter matting, larger particles are captured and the service life of the filter element is significantly extended.

Compressor with variable speed drive

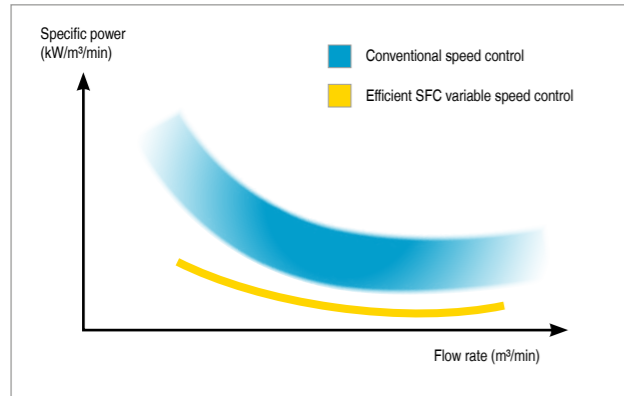

Optimised specific power

The variable speed rotary screw compressor is the most heavily loaded piece of equipment in every compressor station. FSD-SFC models are therefore designed to provide maximum efficiency without running at extreme speeds. This saves energy, maximises service life and enhances reliability.



Separate SFC control cabinet

The SFC (SIGMA FREQUENCY CONTROL) variable speed drive is housed in its own control cabinet to shield it from heat from the compressor. A separate fan keeps operating temperatures in the optimum range to ensure maximum performance and service life from the SFC unit.

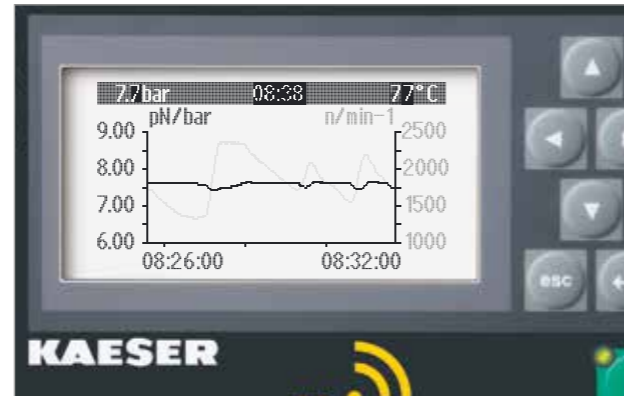

Precision pressure control

The flow rate can be adjusted within the control range according to pressure to suit actual compressed air demand. As a result, operating pressure is precisely maintained to within ± 0.1 bar. This allows maximum pressure to be reduced which saves both energy and money.



EMC-certified

It goes without saying that the SFC control cabinet and SIGMA CONTROL 2 are tested and certified both as individual components and as a complete system to EMC directive EN 55011 for Class A1 industrial power supplies.



FSD series – water-cooled...

...with plate heat exchanger

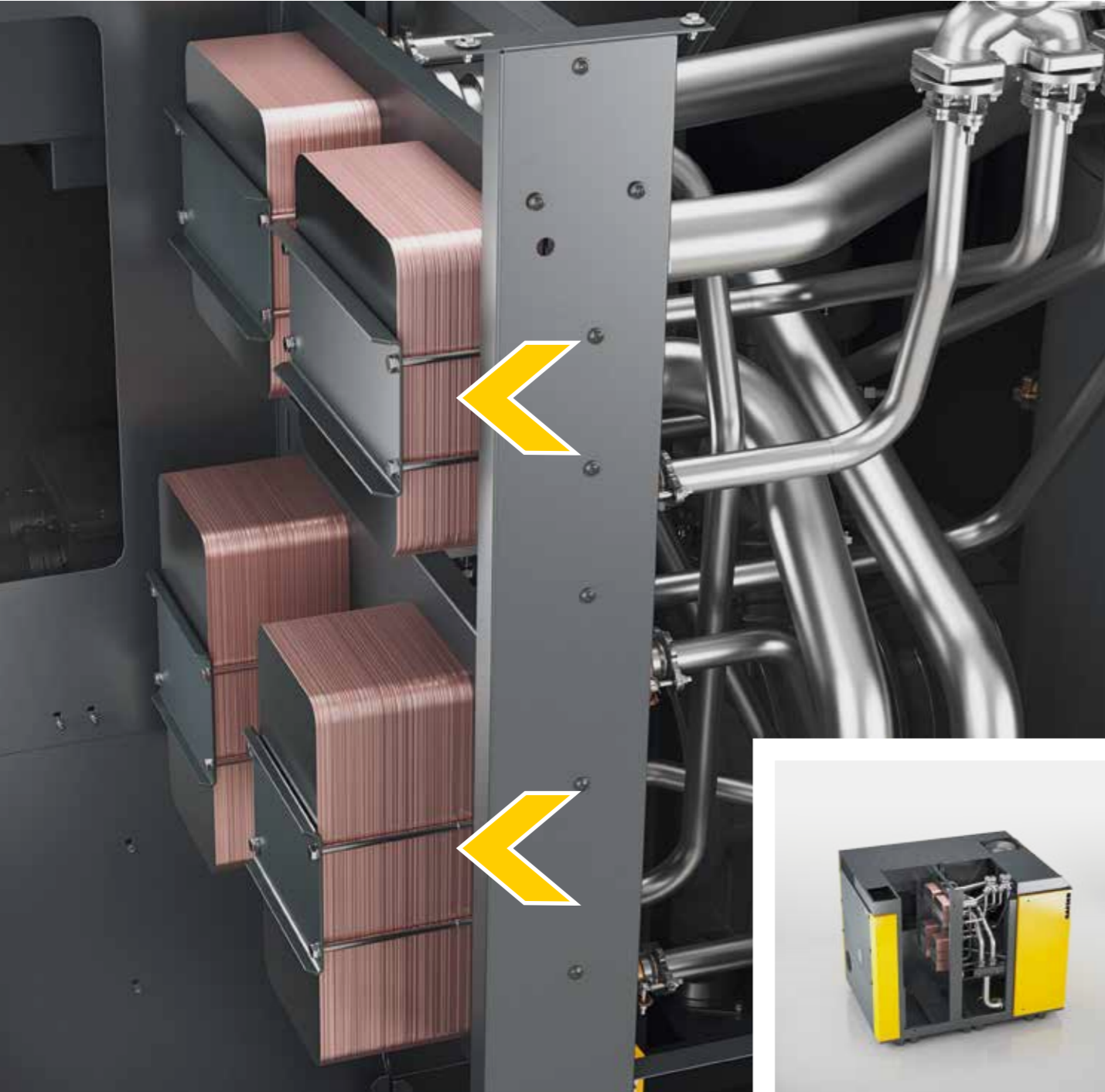

Four stainless steel plate heat exchangers, soldered with copper plates, ensure exceptional heat transfer thanks to the high cooling capacity of optimised plate corrugation –

the perfect choice for applications with clean compressor cooling water.

...with shell and tube heat exchanger



Providing sufficient cooling performance, shell and tube heat exchangers made of copper-nickel alloy (CuNi10Fe) in plate heat exchangers are less prone to contamination, are more robust and can be mechanically cleaned. Furthermore, the cooler inserts can be changed very easily.

In addition they are seawater-proof, which means that they are suitable for compressors used in shipping operations and also operate with minimal pressure loss.

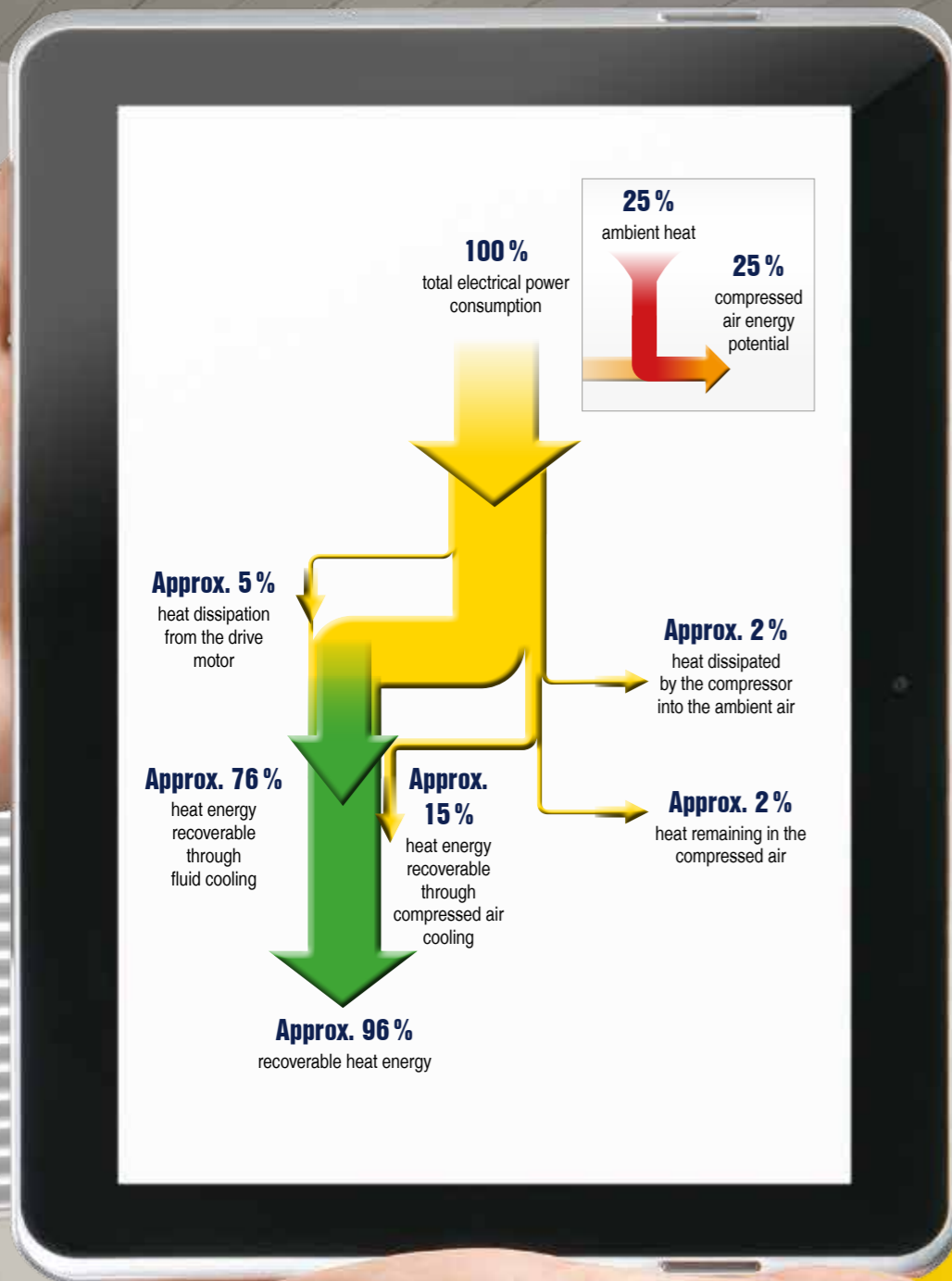

Savings calculation for warm air heat recovery in terms of fuel oil (FSD 575)

Maximum available heat capacity:	333 kW	
Fuel value per litre of fuel oil:	9.861 kWh/l	
Fuel oil heating efficiency:	0.9	
Price per litre of fuel oil:	0.60 €/l	1 kW = 1 MJ/h x 3.6
Cost saving:	$\frac{333 \text{ kW} \times 2000 \text{ h}}{0.9 \times 9.861 \text{ kWh/l}}$	x 0.60 €/l = € 45,026 per year

Further information regarding heat recovery:
<http://www.kaeser.com/int-en/products/rotary-screw-compressors/heat-recovery/>

Heat recovery

Cost-effective heating

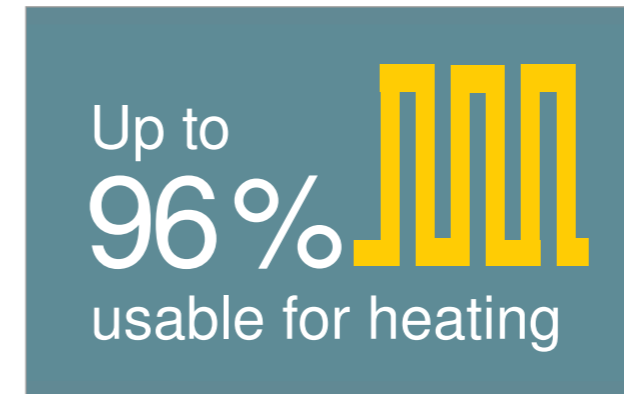

Heat recovery is a win

Amazingly, 100 % of the electrical drive energy input to a compressor is converted into heat energy. Of that, up to 96 % is available for heat recovery purposes. Use this potential to your advantage!

Space heating with warm exhaust air

Heating made easy: thanks to the high residual thrust radial fan, exhaust (warm) air can be easily ducted away to spaces that require heating. This simple process is thermostatically controlled.



Process, heating, and service water

Hot water, up to 70 °C, can be produced from reusable compressor heat via PWT* heat exchanger systems. Please contact KAESER regarding higher temperature requirements.

* optionally installed within the package

Clean hot water

If no other water circuit is interconnected, special fail-safe heat exchangers meet the highest demands for the purity of the water being warmed, as is the case with cleaning-water in the food industry for example.

Heat recovery

Energy-saving, versatile and flexible



Effective thermal management

FSD packages with integrated heat recovery are equipped with four electromotive temperature control valves (ETM), two apiece for the heat recovery system and the package oil cooler.



Flexible temperature

The SIGMA CONTROL 2 controller enables precision setting of the required aircend discharge temperature of the compressed air needed in order to achieve the desired water discharge temperature from the heat recovery system.



Save energy with the SIGMA CONTROL 2

If all of the heat energy is drawn-off by the heat recovery system, then the SIGMA CONTROL 2 recognises that cooling is no longer required on the package cooler and, as a result, the fan on the fluid cooler is shut off. This achieves further energy savings.



Winter ON - Summer OFF

If no heat recovery is required, such as in the summer months for example, this can be simply deactivated using the SIGMA CONTROL 2: under ETM control, the package immediately starts to operate once again at maximum energy efficiency with lowest possible aircend discharge temperature.



Equipment

Complete unit

Ready for operation, fully automatic, silenced, vibration damped, all panels powder coated. Can be used in ambient temperatures up to +45 °C. Service-friendly design: bearings for drive and fan motors can be lubricated externally.

Airend

Genuine KAESER single-stage rotary screw airend with energy-saving SIGMA PROFILE rotors and cooling-fluid injection for optimised rotor cooling. 1:1 direct drive.

Fluid and air flow

Dry air filter with pre-separation, inlet silencer, pneumatic intake and venting valve, cooling fluid reservoir separator tank with three-stage separation system; safety valve, minimum pressure check valve, Electronic Thermal Management (ETM) and eco fluid filter in cooling circuit, fluid and compressed air aftercooler (air-cooled as standard); two fan motors (one with variable speed control); KAESER centrifugal separator with electronically controlled ECO-DRAIN condensate drain (high efficiency and zero pressure loss); stainless steel pipework and centrifugal separator.

Water-cooled version

Fluid and compressed air aftercooler implemented as water-cooled plate-type heat exchanger or as tube-type heat exchanger (optionally also seawater-resistant); water circuit in stainless steel piping 1.4301.

Optimised separator system

The combination of flow-optimised pre-separation and special separator cartridges results in minimal remaining fluid content of < 2 mg/m³ in the compressed air. This separator system requires less maintenance.

Internal heat recovery (optional)

Optionally equipped with integrated fluid-water plate heat exchangers and additional fluid thermostats; external connections.

Electrical components

Super premium efficiency IE4 drive motor with three Pt100 winding temperature sensors for motor monitoring, IP 54 control cabinet, control cabinet ventilation, automatic star-delta protection combination, overload relay, control transformer; for SFC version: frequency converter for drive motor.

SIGMA CONTROL 2

“Traffic light” style LED indicators show operational status at a glance, plain text display, 30 selectable languages, soft-touch keys with icons, fully automated monitoring and control. Selection of Dual, Quadro, Vario, Dynamic and continuous control as standard. Interfaces: Ethernet; additional optional communication modules for: Profibus DP, Modbus, Profinet and Devicenet. SD-card slot for data-logging and updates; RFID reader, web server.

Efficient dynamic control

The dynamic control feature calculates run-on times based on the measured motor winding temperature. This reduces idling times and energy consumption. Additional control options are stored in the SIGMA CONTROL 2 and can be called up as required.

SIGMA AIR MANAGER 4.0

The further-refined adaptive 3-D^{advanced} Control predictively calculates and compares various operating scenarios and selects the most efficient to suit the compressed air application's specific needs.

The SIGMA AIR MANAGER 4.0 therefore optimally adjusts flow rates and compressor energy consumption in response to current compressed air demand. This powerful feature is made possible by the integrated industrial PC with multi-core processor in combination with the adaptive 3-D^{advanced} Control. Furthermore, the SIGMA NETWORK bus converters (SBC) provide a host of possibilities to enable the system to be individually tailored to meet exact user requirements. The SBC can be equipped with digital and analogue input and output modules, as well as with SIGMA NETWORK ports, to enable seamless display of flow rate, pressure dew point, power or alarm message information.

Amongst other key features, the SIGMA AIR MANAGER 4.0 provides long-term data storage capability for reporting, controlling and audits, as well as for energy management tasks as per ISO 50001.

(See image to the right; excerpt from the SIGMA AIR MANAGER 4.0 brochure)

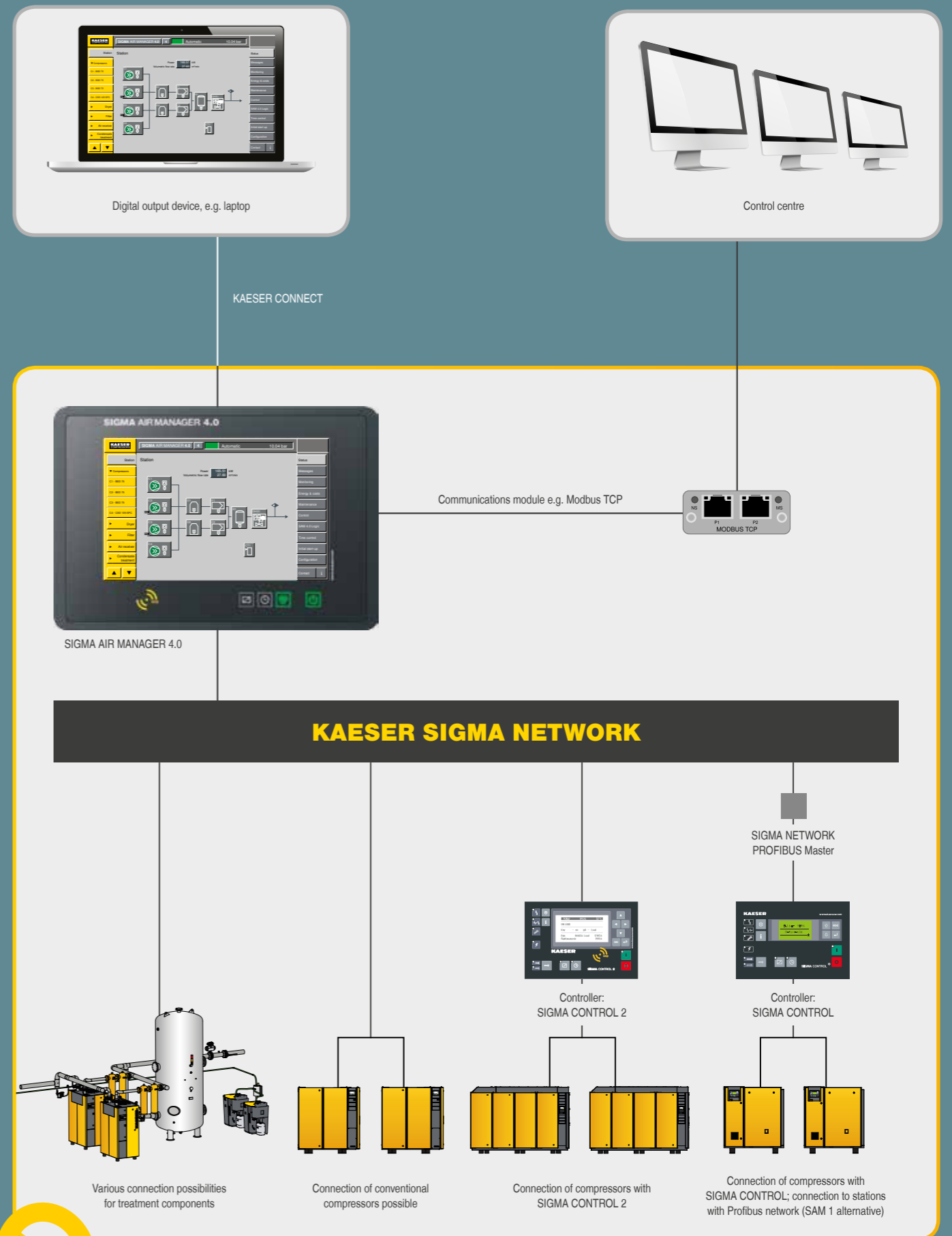

Secure data – secure business!

Technical specifications

Standard version

Model	Operating pressure bar	Flow rate *) Overall system at operating pressure m³/min	Max. working pressure bar	Drive motor rated power kW	Dimensions W x D x H mm	Compressed air connection	Sound pressure level **) dB(A)	Mass kg
FSD 475	7.5	48.20	8.5	250	3495 x 2145 x 2360	DN 150	79	6580
	10	37.63	12					
	13	29.52	15					
FSD 575	7.5	58.40	8.5	315	3495 x 2145 x 2360	DN 150	79	6750
	10	47.57	12					
	13	37.00	15					



SFC - Version with variable speed drive

Model	Operating pressure bar	Flow rate *) Overall system at operating pressure m³/min	Max. working pressure bar	Drive motor rated power kW	Dimensions W x D x H mm	Compressed air connection	Sound pressure level **) dB(A)	Mass kg
FSD 475 SFC	7.5	10.6 - 49.87	8.5	250	3740 x 2145 x 2360	DN 150	79	6930
	10	9.93 - 44.08	12					
FSD 575 SFC	7.5	13.33 - 59.83	8.5	315	3740 x 2145 x 2360	DN 150	80	7300
	10	12.9 - 50.85	12					
	13	11.55 - 45.00	15					

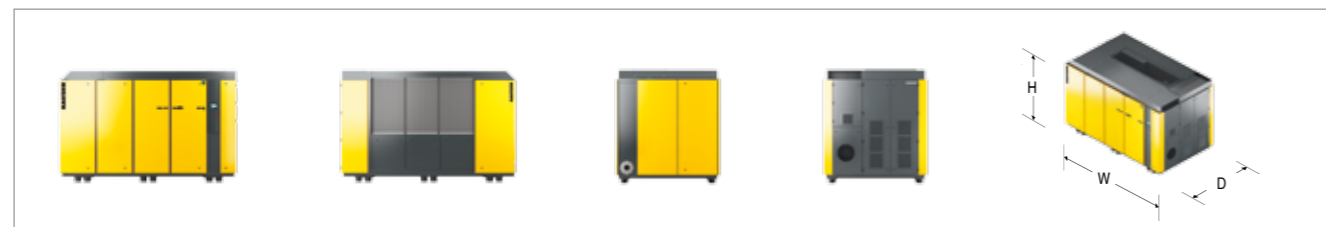

*) Flow rate complete system as per ISO 1217: 2009 Annex C: Absolute inlet pressure 1 bar (a), cooling and air inlet temperature 20 °C

**) Sound pressure level as per ISO 2151 and basic standard ISO 9614-2, tolerance: ± 3 dB (A)

Note for water-cooled version: The technical specifications for 'Dimensions', 'Sound pressure level', and 'Mass' differ from the air-cooled version.

How it works

The rotary screw airend (3) is driven by an electric motor (4). The fluid injected primarily for cooling purposes during the compression process is separated once again from the air in the fluid separator tank (5). The integrated fan ensures cooling of the compressor package and also provides sufficient flow of cooling air through the oil cooler and compressed air aftercooler (6 and 9).

The controller ensures that the compressor produces compressed air within the set pressure limits. Safety functions protect the compressor against failure of key systems via automatic shutdown capability.

- (1) Intake filter
- (2) Intake valve
- (3) SIGMA PROFILE airend
- (4) IE4 drive motor
- (5) Fluid separator tank
- (6) Compressed air aftercooler
- (7) KAESER centrifugal separator
- (8) ECO-DRAIN condensate drain
- (9) Fluid cooler
- (10) Electronic Thermal Management
- (11) Eco fluid filter
- (12) Fluid cooler radial fan with variable speed control
- (13) Compressed air aftercooler radial fan



The world is our home

As one of the world's largest compressed air systems providers and compressor manufacturers, KAESER KOMPRESSOREN is represented throughout the world by a comprehensive network of branches, subsidiary companies and authorised partners.

With innovative products and services, KAESER KOMPRESSOREN's experienced consultants and engineers help customers to enhance their competitive edge by working in close partnership to develop progressive system concepts that continuously push the boundaries of performance and compressed air efficiency. Moreover, the decades of knowledge and expertise from this industry-leading system provider are made available to each and every customer via the KAESER group's global computer network.

These advantages, coupled with KAESER's worldwide service organisation, ensure that every product operates at the peak of its performance at all times and provides maximum availability.



KAESER COMPRESSORS Australia Pty. Ltd.

Locked Bag 1406 – Dandenong South – Vic. 3164

45 Zenith Road – Dandenong – Vic. 3175

Phone: +61 3 9791 5999 – Fax: +61 3 9791 5733 – E-mail: info.australia@kaeser.com – www.kaeser.com